

REVISION	DRAWN BY	REVISION DESCRIPTION	DATE	APPROVED ENGINEER
	dmar		29-8-2019	

JRTR77...

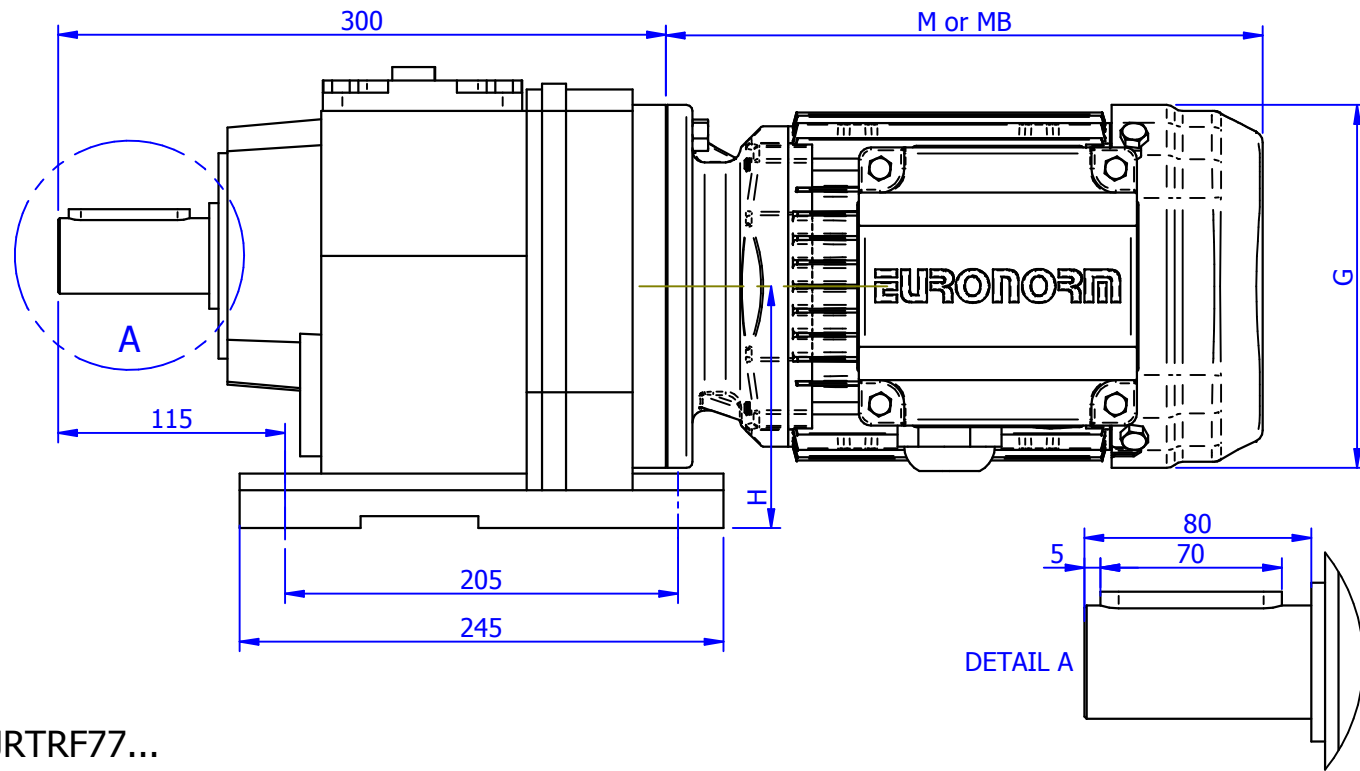

GENERAL NOTES:

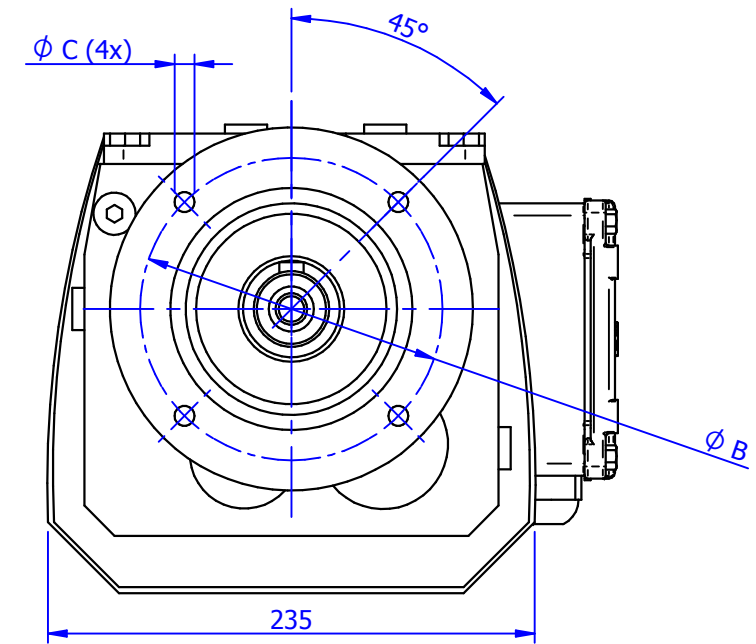
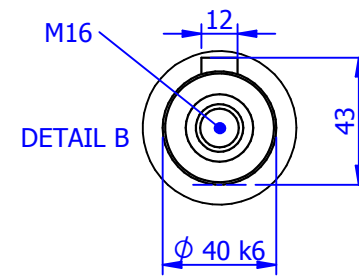
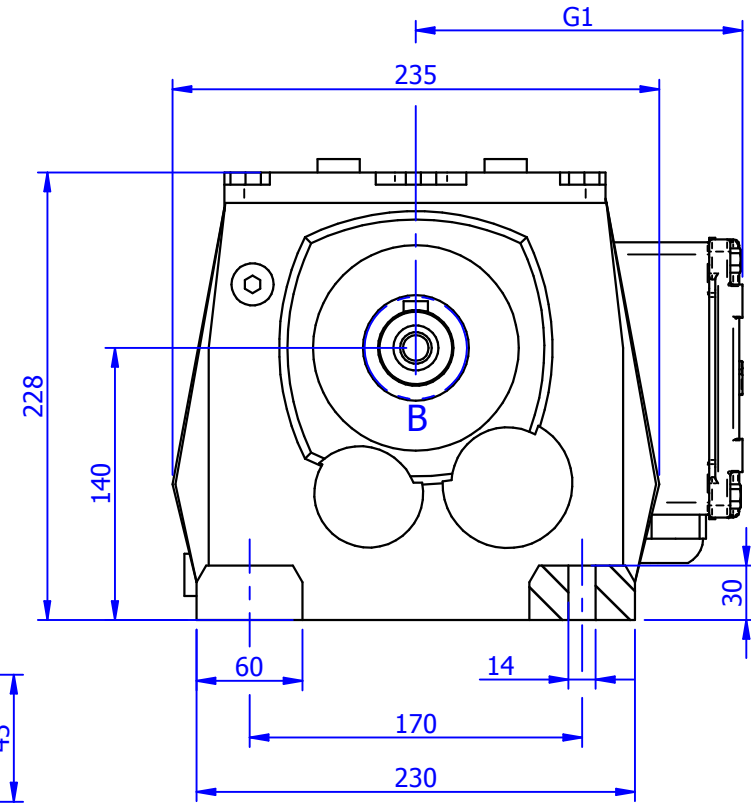

JRTRF77...

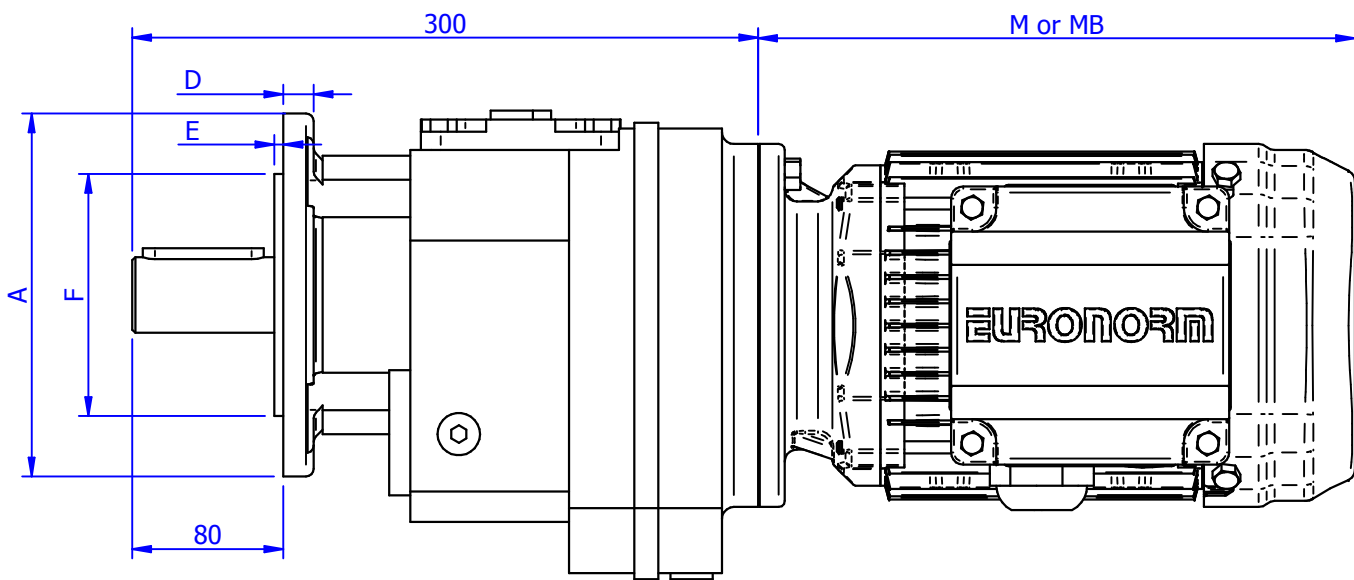

Output flange dimensions	Flange size I	Flange size II	Flange size III
A	x	250	300
B	x	215	265
C	x	13,5	13.5
D	x	15	18.5
E	x	4	4
F	x	180j6	230j6

IEC size motor	JDS63 S/M/L	JDS71 S/M	JDS80 S/M	JDS90 M/L	JDS100 M	JDS112 M	JDS132 S/M
G	120	135	156	177,5	189	221	221
G1	108	127	137	148	156	171	171
M	234	263	303	326	388	437	489
MB (brake version)	258	288	340	370	430	480	480

QUANTITY:	DRAWING DESCRIPTION						
01	JRTR..77..						
		© EURNORM DRIVE SYSTEMS B.V., THIS DOCUMENT CONTAINS CONFIDENTIAL AND PROPRIETARY INFORMATION WHICH, UNLESS OTHERWISE EXPRESSLY AGREED TO IN WRITING BY EURNORM, REMAINS THE SOLE PROPERTY OF EURNORM, AND MAY NOT BE DISCLOSED, COPIED, REDISTRIBUTED, RETRANSMITTED, PUBLISHED OR USED TO CREATE DERIVATIVE WORKS.					
		PROJECTION:	THIRD PROJECTION	DRAWN BY:	Engineering		
DATE DRAWN:	29-8-2019	SCALE:	1:2,5	SIZE:	A3	REVISION:	3
ORDER NUMBER:		DRAWING NUMBER:		SHEET:			