

**WEA/JL-serie**

# Manual Slewing Drives

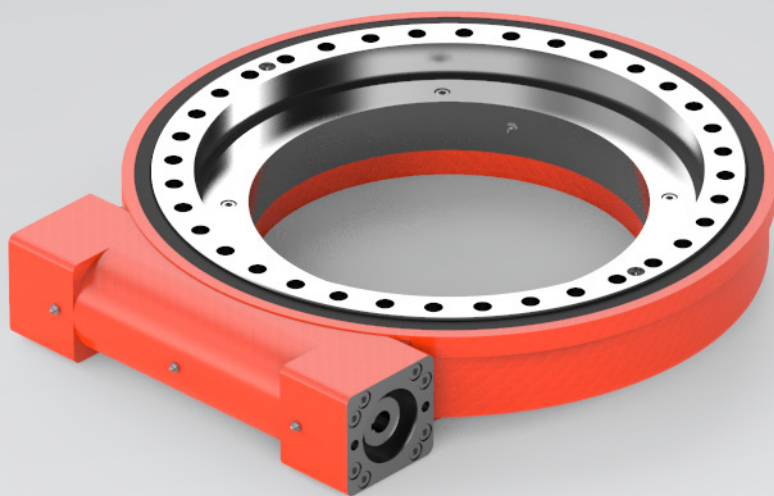

UNIT CODE: B A XXX – ZF – CD			
B:	Group Slew drive		
A:	Slewing ring structure		
X:	Size		
F:	Other characteristics		
	0	With encoder output & Ø25mm shaft entrance	1, 2, ... Other special configurations
C:	Side of motor installation		
	L	Left side	
	R	Right side	
D:	Threads		
	M	Metric threads	
	I	Imperial threads	

## Notice

- The following text includes notices and procedures which should be observed when installing the slew drives and during the maintenance.
- Read carefully this manual before any operation is performed. The working features can only be ensured if the steps have been followed correctly.
- All steps listed below must be carried out by qualified personal.
- This manual should be kept near the structural element and has to be always accessible to the personal.
- The purchaser is responsible for protective measures and installation of all the equipment.
- Please contact our technical department for any further assistance.
- The technical data for each slew drives can be found in our product catalogue.

## Inhoud

Notice .....	1
Contents.....	3
1. Transport, handling and storage provision .....	3
2. Installation.....	3
2.0 Previous checks.....	3
2.1 Clean the slew drive and the mounting structure .....	3
2.2 Determine permissible flatness deviation $\delta p$ and perpendicular deviation $\delta w$ of the supporting surfaces of the mounting structure.....	4
2.3 Lubricate the Slew drive or check oil level.....	5
2.4 Choice of mounting bolts .....	6
2.5 Choice of tightening torques .....	7
2.6 Install the Slew drive .....	8
2.7 Install the motor .....	9
3. Operation test.....	9
4. Maintenance/safety checks and lubrication .....	9
4.1 Checking mounting bolts .....	9
4.2 Re-lubrication of slew drive .....	10
4.3 Re-lubrication intervals .....	10
5. Last indications .....	11
ANNEX I .....	12
Optimum grease type properties and re-lubrication intervals .....	12

# Contents

## 1. Transport, handling and storage provision

- Transport only in horizontal position, Impacts should be avoided.
- Wear work gloves and be careful when handling the Slew drives. Slew drives are generally provided with threaded holes in the inner and in the outer ring into which eyebolts can be assembled. This enables safe handling on a hoisting device. The threaded length of the bolt should be at least 1.5 times the diameter of the bolt. It should be transported without other assembled components.
- Store only in horizontal position and in closed rooms. Keep it away from the areas where it could get wet. The surface corrosion protection holds for approx. 5 months in the enclosed packaging. Longer periods of storage require special protective measures.

## 2. Installation

### 2.0 Previous checks

- Check the slew drive for physical damage.
- Check that the slew drive turns smoothly. In case the slew drive does not turn, please check whether there is impediment, or check connection power (hydraulic or electric) to be sure it is properly in supply.
- If the slew drive makes noise, please check whether lubrication is good enough or the flatness of the slew drive is as required, or the rotation frequency is as expected.
- Check whether the dimension of the bolt is as expected.
- Check whether the type of the bolt (metric or imperial) is as expected.

### 2.1 Clean the slew drive and the mounting structure

- Remove extraneous materials from supporting surfaces.
- Clean the outer mounting surfaces using a cold solvent that doesn't damage the rubber seals.
- Cleaning a Slew drive with steam jet or high-pressure cleaner is not permissible.

## 2.2 Determine permissible flatness deviation $\delta_p$ and perpendicular deviation $\delta_w$ of the supporting surfaces of the mounting structure.

The surfaces that are going to be in contact with the slew drive must satisfy some specifications of flatness and perpendicular deviation which are described below.

The maximum value for flatness deviation  $\delta_p$  (waviness) along the circumference can be reached only once each 180 deg. The form must resemble a sine curve that gradually rises and falls. The maximum values for each drive are the ones listed in the table below.

Slew Drive Size		WEA7	WEA9	WEA12	WEA14	WEA17	WEA19	WEA21	WEA25
Perpendicular $\delta_w$ deviation supporting surface	Degree	0,09	0,09	0,09	0,09	0,09	0,09	0,09	0,09
	[mm]	0,11	0,16	0,23	0,26	0,32	0,4	0,42	0,49

Table 1: Permissible flatness deviations for Slew drives mounting surface

Permissible perpendicular deviation  $\delta_w$  (tilting) is based on the flange width and must be measured in the transverse direction. The maximum values for each drive are the ones listed in the table below.

Slew Drive Size		WEA7	WEA9	WEA12	WEA14	WEA17	WEA19	WEA21	WEA25
Flatness $\delta_p$ deviation supporting surface	[mm]	0,08	0,08	0,10	0,10	0,10	0,12	0,15	0,15

Table 2: Permissible perpendicular deviations for Slew drives mounting surface

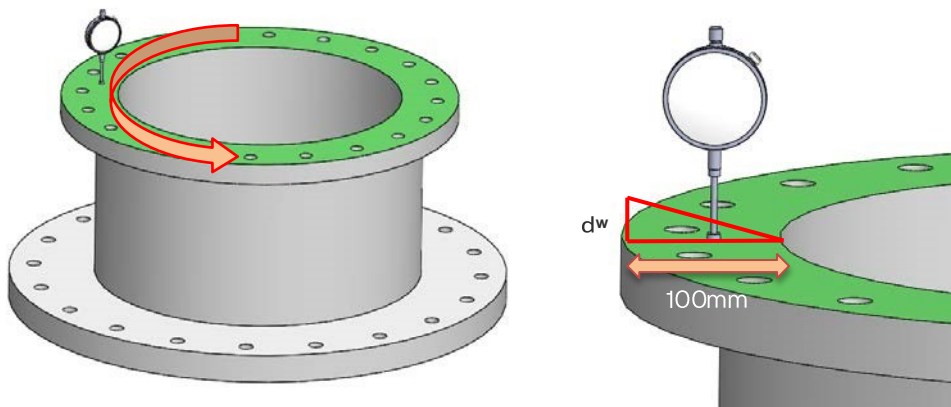

Image 1: Flatness deviation measuring procedure (left).

## 2.3 Lubricate the Slew drive or check oil level

There are three places which need to be lubricated: the slewing ring raceway, the screw worm and the bearings.

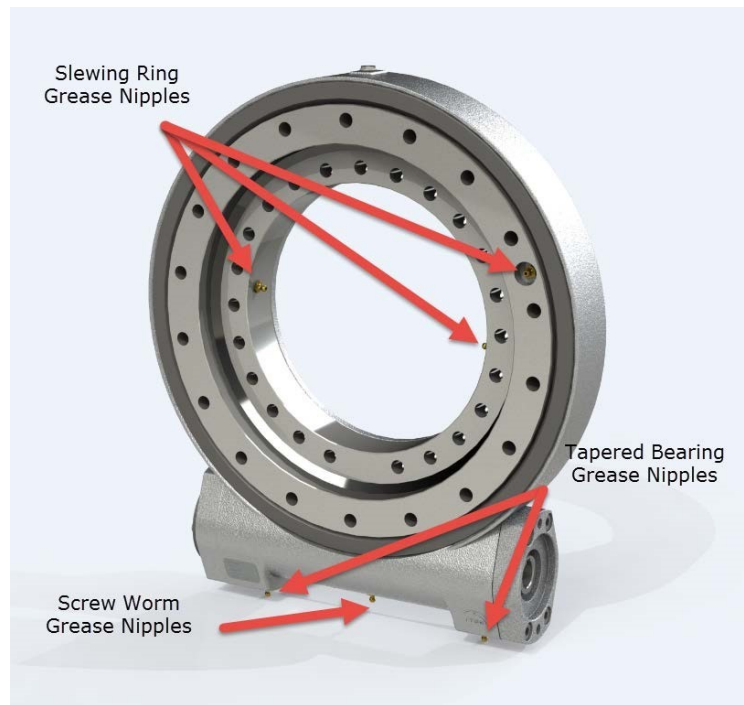

Image 2: Explanation on the grease nipples of the slew drive

Slew drives are supplied with slewing ring raceway, screw worm and bearings pre-lubricated. They shall be greased again prior to initial operation and re-lubricated accordingly depending on working conditions.

Suitable grease types for normal cases are listed on table 3:

Recommended grease type	Mineral or Synthetic grease. (In case of using Synthetic grease type, be sure that is 100% compatible with any mineral grease.)
EP (Extreme Pressure)	YES
Consistency NLGI (ISO2137)	Grade 2
Oil Separation	< 3%
Corrosion and water protection	YES
Acceptable Thickeners	Calcium, Lithium or Aluminium sulphates
Temperature range in °C	-20°C / +125°C
Base oil viscosity (at 40°C)	>125mm <sup>2</sup> /s
Welding Load	>200kg

Table 3: Table of standard grease properties

Parts of the slew drive that need lubrication	Screw Worm	Ring raceway	Tapered Bearing
Quantity of grease	60cc	10cc each 250mm of raceway diameter	10cc each

Table 4: Grease quantity for each part of the drive

In case the drive has to withstand extreme loads and working conditions or lower re-lubrication intervals are required, optimum grease can be used (See Annex I).

## 2.4 Choice of mounting bolts

As the gearbox manufacturer, we do not recommend the use of the fasteners that we supply only for transportation. Please take great care in specifying this item which will attach our product to yours.

- Prescribed sizes, number and quality grades shall be used.
- All the holes in the slew drive must be used to fix it to the mounting structure.
- Grip ratio (grip length to diameter of bolt) shall be observed, from minimum  $\geq 2$  to maximum  $\leq 10$ .
- Bolts with a fully threaded shaft should not be used.
- Slew drive function, lifespan, and durability of the bolt connection are affected in case of non-compliance.
- When the permissible interfacial pressure is exceeded, use washers of appropriate size and strength.
- Do not reuse bolts, nuts and washers. Replace after certain amount of time.

Materials	Max. surface pressure in MPa
50Mn / C45N / 46Cr2N	420
42CrMo4	700

Table 5: Table of admissible interfacial pressures

## 2.5 Choice of tightening torques

Mounting bolts are in normal cases adequately secured by proper preloading.

Use of split rings, split washers, etc. is not permissible.

Mounting bolt Dimension	Tightening torque $M_A$ in Nm Quality class 10.9
M6	$15 \pm 1$
M8	$37 \pm 3$
M10	$72 \pm 6$
M12	$126 \pm 10$
M16	$312 \pm 25$
M20	$609 \pm 50$

Table 6: Tightening torques for Metric mounting bolts (non-lubricated thread)

Mounting bolt Dimension	Tightening torque $M_A$ in lbs-ft Quality SAE grade 8
1/4-20 UNC	$12 \pm 1$
5/16-18 UNC	$24 \pm 2$
3/8-16 UNC	$45 \pm 4$
1/2-13 UNC	$110 \pm 7$
5/8-11 UNC	$210 \pm 18$
3/4-10 UNC	$380 \pm 36$

Table 7: Tightening torques for Imperial mounting bolts (non-lubricated thread).

## 2.6 Installing the Slew drive

- Determine the main load-carrying zone.
- The soft zone is marked with a filling plug.
- Remove the shipping bolts. Do not remove the shoulder bolts or the Allen bolts that fix the top plate and the housing to the slewing ring.
- With a gauge, check whether the Slew drives supporting surfaces of are fully supported by the mounting structure.
- The Slew drive shall be mounted in an unloaded condition.
- Assemble the flanges to the housing and the slewing ring.
- In case the slew drive is used in vertical /radial position (horizontal rotational axis), the slew drive must be installed with the screw worm in the lower part.



The following procedure shall be followed in order to avoid deviations between bolt tightening forces.

- Slightly apply thread locker to the bolt threads (last three to five filets) in order to ensure uniform frictional resistance.
- Preload the bolts incl. washers, if required, crosswise in 3 steps: 30%, 80% and 100% of the tightening torque. The scheme below shows the order to be followed when tightening the bolts

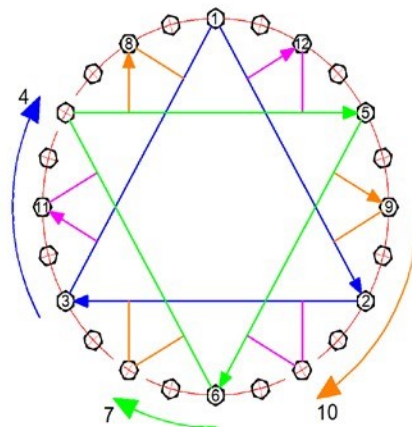

- Once the screw is tightened, Please make a mark in the surface of the screw and other structure surface. It is useful to inspect it.

## 2.7 Install the motor

- Check the motor before installing it, whether the shield is intact, the power is expected, or there is electric protector for motor (in case of AC or DC motor).
- In case of using a flange to install the motor to the slew drive it is recommended to apply gasket sealant between both surfaces or install an O-ring between them. ○ Connect it to the power supply.
- Begin to operate the motor under no load. ○ When the operation is correct, then increase the load gradually.

## 3. Operation test

If the mounting bolts are properly tightened and the drive motor is correctly connected, then the Slew drive shall rotate uniformly. Deviations of the mounting structure and the effect of extraneous loads can strongly impact the friction torque.

- Rotate mounted slew drive several times.
- Check whether slew drive runs smoothly without ripple.
- Perform further test under full load.
- After operation test, recheck the tightening torques of mounting bolts.

## 4. Maintenance/safety checks and lubrication

### 4.1 Checking mounting bolts

To compensate the possible settling, it is necessary to retighten the bolts to the prescribed torque. This shall be done after no more than 100 hours of the first operation and without external load applied to the bolt connection. It is recommended to inspect the bolts every year (using the marks done during assembly) and retighten the bolts if necessary. If the slew drive is supplied with motorization (reducer or motor) then the bolts that fix those parts between them and to the drive should also be checked.

The inspection frequency can be increased if there is no special working or extreme weather conditions. In case of loose bolts, replace those bolts, nuts and washers with new ones.

## 4.2 Re-lubrication of slew drive

Suitable substitute lubricants can be found in Table 3. Manufacturer provisions about handling the respective lubricants must be observed.

Follow the procedure below:

- To lubricate the slewing ring, inject grease into one grease nipples on the inner ring while rotating the Slew drive at least 180°.
- Inject grease through the other grease nipple on the inner ring while rotating the Slew drive at least 180°.
- In case none of these grease nipples is available the slewing ring can be greased by the grease nipple on the top plate. To achieve the proper lubrication from these lubrication points the slewing ring must do a whole turn.
- For the screw worm and bearings lubrication, inject grease in the proper grease nipples for at least 3 turns on the screw worm.

## 4.3 Re-lubrication intervals

Re-lubrication is needed to assure a minimum quality on the grease inside the drive. In case no comparative results are available, the following table can be used as a reference.

Working conditions	Slewing Ring and Screw Worm Re-lubrication intervals
Rotational speeds <0,5rpm Non extreme environmental conditions (solar trackers)	Every 400 hours of operation or once every 12 months
Rotational speeds >0,5rpm Non extreme environmental conditions (man lift, industrial applications)	Every 200 hours of operation or once every 6 months
Extreme climatic conditions (sea / desert / Arctic climate / very dirty surrounding) (tunnelling machines/steel mills)	Every 100 hours of operation or once every 3 months
Bearing re-lubrication intervals	
All Working conditions	Every 400 hours or every 12 months

Table 8: Re-greasing intervals depending on working conditions

The specified values are valid for the following conditions:

- Operating temperature on Slew drive < 65°C
- Drive rotational speed < 1rpm
- Low to medium loads

The table can never replace values established through experience. The most frequent cause of failure of Slew drives is insufficient lubrication.

Slew drives shall generally be re-lubricated after every cleaning and also before and after long inactive periods, e.g. for crane and construction machines during winter months.

Cleaning a Slew drive with steam jet or high-pressure cleaner is not permissible.

## **5. Last indications**

The instructions give you the information you need to be able to correctly install and maintain a Slew drive.

Please always check that you are working with the latest revision.

These instructions shall be sent to all new customers. All work steps listed here are to be executed by suitably qualified personnel.

Please do not hesitate to contact our Engineering Department for any further assistance.

All the information in this document has been carefully evaluated and checked. We do not, however, accept responsibility for any omissions or errors.

Euronorm accepts no liability for:

1. Non-compliance with Installation and Maintenance Instructions
2. Failure to pass on content to third part.

## ANNEX I

### Optimum grease type properties and re-lubrication intervals

In case the loads applied to the drive are extreme loads or lower re-lubrication intervals are required, an optimum kind of grease could be used. The recommended properties for this kind of grease are the one shown in the table below.

Recommended grease type	Mineral or Synthetic grease. In case of using Synthetic grease type, be sure that is 100% compatible with any mineral grease.
EP (Extreme Pressure)	YES
Consistency NLGI (ISO2137)	Grade 2
Oil Separation	< 2%
Corrosion and water protection	YES
Acceptable Thickeners	Calcium, Lithium or Aluminium sulphates
Temperature range in °C	-20°C / +150°C
Base oil viscosity (at 40°C)	>350mm <sup>2</sup> /s
Welding Load	>600kg

Table A.1: Table of optimum grease properties

On the following table general re-lubrication intervals can be found. In case some tests approaching real working conditions have been performed to check the optimum re-lubrication intervals the table cannot replace the values established through experience.

Working conditions	Slewing Ring and Screw Worm Re-lubrication intervals
Rotational speeds <0,5rpm Non extreme environmental conditions (solar trackers)	Every 1200 hours of operation or once every 36 months
Rotational speeds >0,5rpm Non extreme environmental conditions (man lift, industrial applications)	Every 600 hours of operation or once every 12 months
Extreme climatic conditions (sea / desert / Arctic climate / very dirty surrounding) (tunnelling machines/steel mills)	Every 300 hours of operation or once every 6 months
Bearing re-lubrication intervals	
All Working conditions	Every 1200 hours or every 36 months

*Table A.2: Re-greasing intervals depending on working conditions*



**HQ & Assembly Center  
Netherlands and Vlanders**

Hub van Doorneweg 8  
2171 KZ Sassenheim, Netherlands  
**Tel:** +31 252 228 850  
**Mail:** [info@jie-euronorm.com](mailto:info@jie-euronorm.com)

**Office  
D-A-CH Region**

Frankenstraße 5  
48734 Reken, Germany  
**Tel:** +49 (0) 174 25 10 609  
**Mail:** [antriebe@jie-euronorm.com](mailto:antriebe@jie-euronorm.com)

**Office & Assembly Center  
Eastern Europe**

Biała-Parcela 13  
98-350 Biała, Poland  
**Tel:** +48 692 476 519  
**Mail:** [reduktor@jie-euronorm.com](mailto:reduktor@jie-euronorm.com)

**Office  
France and Wallonian Region**

39, Rue de l'Ornoy  
1435, Mont-Saint-Guibert, Belgium  
**Tel:** +31 252 228 850  
**Mail:** [transmission@jie-euronorm.com](mailto:transmission@jie-euronorm.com)